

TR-JB07/WM03-IN 3-inch Fixed Dome Outdoor Wall Mount

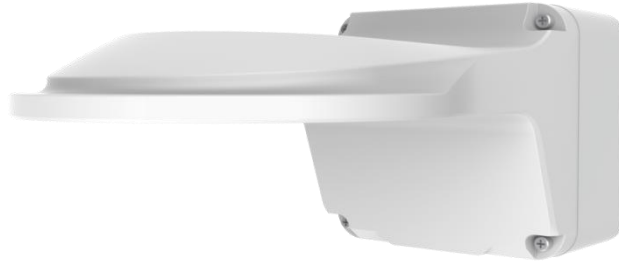

Specifications

Bracket	TR-JB07/WM03-IN
Application	Outdoor, wall installation for 3-inch fixed dome(Extra back outlet)
Dimensions	233mmx126mmx126mm (9.2" x5" x5")
Weight	0.9kg(1.98lb)
Material	Aluminum alloy

Dimensions

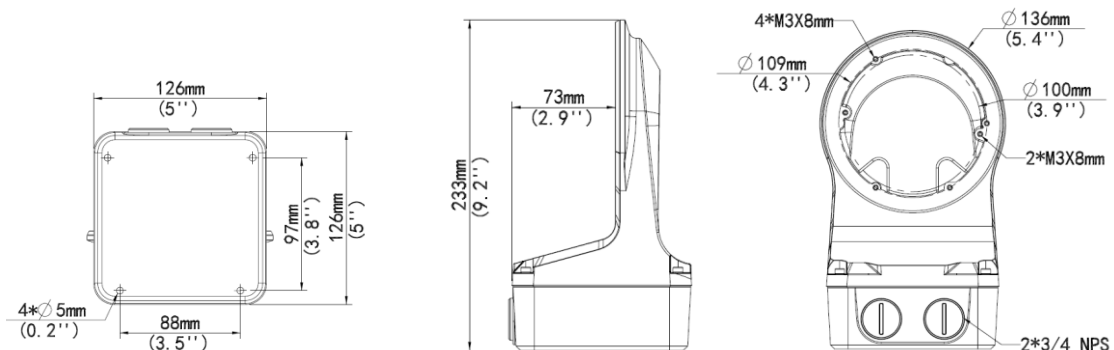

Zhejiang Uniview Technologies Co.,Ltd.

South Tower, Building 10, Wanlun Science Park, 88 Jiangling Road, Hangzhou, P.R.China 310051

Email: overseasbusiness@uniview.com; globalsupport@uniview.com

<http://www.uniview.com>

©2015 Zhejiang Uniview Technologies Co.,Ltd. All rights reserved.

*Product specifications and availability are subject to change without notice.